

Sand-dehydrator (HV_._)

Type	HV-05	HV-10	HV-15
Power (m ³ /h)/(l/s)	5/18	8.5/30	14/50
Efficiency (L) {mm}	3800	4500	5400
Height (H) {mm}	1900	2200	2500
Reservoir diameter (ØA) {mm}	1000	1270	1590
Reservoir height (B) {mm}	640	820	850
Sand slurry pipe length (L1) {mm}	525	575	700
Sandless water pipe length (L2) {mm}	625	675	800
Centre- to- centre distance (L3) {mm}	2750	3350	4000
Sand slurry pipe height (H1) {mm}	990	1270	1550
Sandless water pipe height (H2) {mm}	200	200	200
Transfer hopper height (H3) {mm}	1150	1400	1750
Sand slurry pipe (dp) {mm}	DN100	DN150	DN200
Sandless water pipe (dv) {mm}	DN100	DN150	DN200
Worm diameter (dcs) {mm}	DN150	DN200	DN250
Leechate diversion (de) {mm}	2"	2"	2"
Electrical motor efficiency (kW)	0,37	0,55	0,75

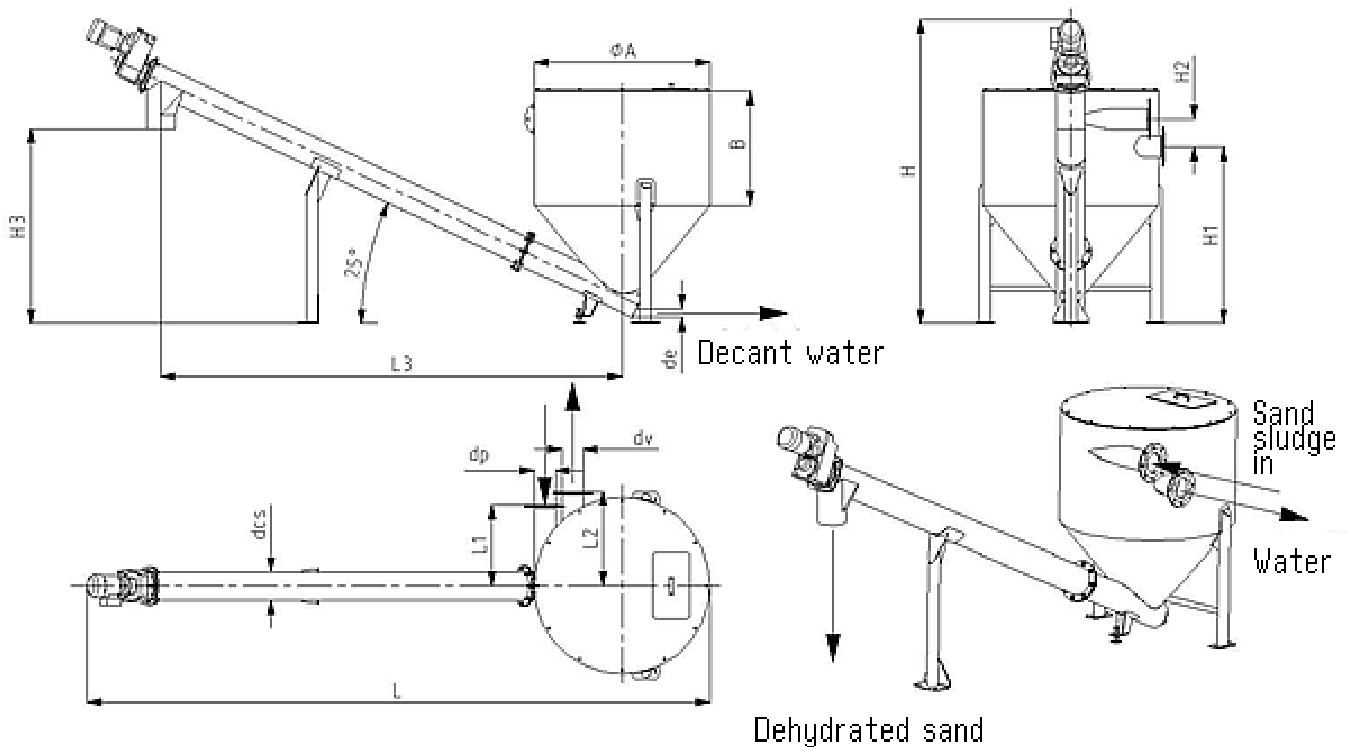

Sand bleeder provide depositing of conducted sand slurry and removing of deposited sand.