

## *Tangential sand-catcher Sunk into the floor (TH\_.\_A)*

Type	TH-150A	TH-100A	TH-75A	TH-55A	TH-30A	TH-20A	TH-10A
Power (m <sup>3</sup> /h)/(l/s)	540/150	360/100	270/75	198/55	108/30	72/20	36/10
Reservoir diameter (ØA) {mm}	2400	1900	1700	1500	1300	1200	950
Reservoir height (B) {mm}	1150	900	850	850	800	800	700
Cone height (C) {mm}	250	200	150	150	150	150	150
Sand field diameter (ØD) {mm}	1100	950	800	800	550	550	450
Sand slurry pipe (ØD be) {mm}	DN600	DN400	DN350	DN300	DN250	DN200	DN200
Sandless water pipe (ØD ki) {mm}	DN600	DN400	DN350	DN300	DN250	DN200	DN200
Height (H1) {mm}	350	300	275	250	180	120	120
Height (H2) {mm}	2000	1600	1550	1600	1450	1450	1200
Lower reservoir height (E) {mm}	1250	1000	1000	1000	850	800	650
Lower cone height (F) {mm}	440	350	300	250	250	250	250
Blender electrical efficiency (kW)	0,25	0,25	0,18	0,18	0,12	0,12	0,12

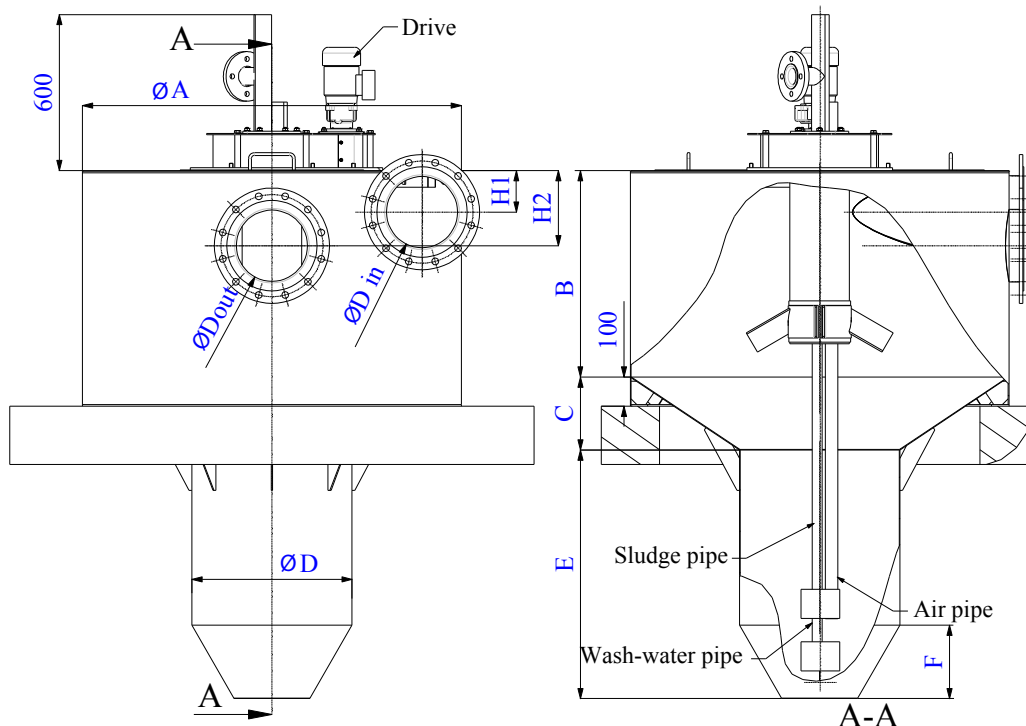

**Tangential sand catcher provide depositing and removing of conducted sewage sand content.**